

# 1" Xtreme Duty AL-Teflon Hand Nozzle

Model DM-700HFR/AMTS1 for Pump & Gravity Dispensing

## Benefits and Features...

- ⇒ For liquids compatible with Aluminum, Stainless & Teflon
- ⇒ Helps prevent spillage during critical liquid transfer operations
- ⇒ Careful fluid control for operator and environmental safety
- ⇒ Ergonomic comfort with long reach 8" spout and pour angle
- ⇒ Simplifies liquid filling & bulk transfer into tanks & containers
- ⇒ Grounding lanyard ring for explosion proof dispensing of flammable solvents or liquids



**Other** high-flow nozzles with 1.5 or 2" F-NPT bases available in AL or PP

## Industrial Applications: General & Heavy Duty Dispensing

- Aluminum & Teflon materials
  - Hose Inlet
  - Extra large flow passage
  - Heavy wall construction
  - Alternative aluminum spouts
- Excellent corrosion resistance to many liquids  
1" F-NPT accepts 3/4" male connector or barb  
Offers low pressure drop and reduces foaming  
For extra strength, durability and longevity  
Curved in 0.930" OD or straight, 0.650" OD



## Specifications

### Model # DM-700HFR Series

**Nozzle Materials of Construction:**

**Hose Inlet:**

**Nozzle weight:**

**Flow/Pressure/Temperature:**

Heavy-duty body: Aluminum, Internals: TFE, 316 SS  
1.0" female NPT, or 3/4" with optional adapter  
4.0 lbs.

Max. 35 Psi, Max. 29 Gpm, 125°F (Up to 150°F with suitable safety equipment.)

## Optional Accessories

Service kit, P# DM-700HFR/AMTS1-SK, replacement parts: Part Key #, 5, 6, 8, 9, 10  
Optional straight spout for small container filling, 0.650" OD x 8" Length  
3/4" hose male-Npt connection base, 316 SS  
3/4" hose barb, 316 SS  
Explosion proof grounding cable kit, P# DM-166GWK .....



## Ordering Specifications

### Replacement Parts

#### Key Part Description

- 1 Cap, aluminum
- 2 Spring, stainless steel
- 3 Disc holder, stainless steel
- 4 Body, aluminum
- 5 Stuffing box, stainless steel
- 6 Packing nut, stainless steel
- 7 Trigger stem, stainless steel
- 8 Disc, Teflon
- 9 Disc washer, stainless steel
- 10 Packing, Teflon
- 12 Handle, plated steel
- 21 Dispensing spout
- 22 Jam nut

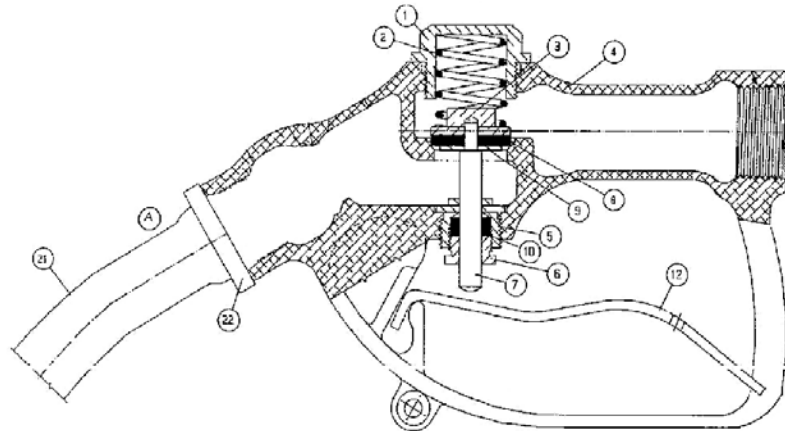

For explosion-proofing, use grounding kit No. DM-166GWK for most mixing or dispensing equipment  
NOTE: For easy "Pick 'n' Match", all components and accessories are sold separately.  
DRUM-MATES® Inc., Mixer & Pump Div., Tel: 800-621-3786 and 609-261-1033, Fax: 609-261-1034