

Xtreme Duty Stainless Hand Nozzle

Model DM-800HFR/L6 Series, 316 SS & Teflon
for Dispensing almost any Liquid, Acid, Solvent or Chemical

Benefits and Applications...

Designed for extreme duty applications, the DM-800HFR/L6 Series dispensing nozzle is used for dispensing most food & beverage liquids, medical, bio-science, pharmaceutical, cosmetic and laboratory chemicals, acids, alkalis, solvents, and other sanitary, corrosive or hazardous materials. All wetted parts are made from 316 stainless steel and Teflon, enabling this nozzle to handle the broadest range of dispensing applications, providing careful fluid control for better operator protection and environmental safety.

The special, built-in, ergonomic, 316SS hose-swivel boosts handling comfort, helps prevent worker wrist injury, and avoid hose tangling or crimping.



DM-800HFR/L6 Nozzle

With careful use it will help prevent spillage during critical liquid transfer or loading operations. It is also a great tool for general repacking of bulk liquids into smaller containers. DM-800HFR/L6 nozzles have heavy wall construction for extra strength and durability. It ensures longevity and tolerance for the most demanding industrial supply operations. The nozzle simplifies liquid filling at the most basic level and furnishes excellent pressure dispensing from all kinds of pumps and works well in gravity feed applications from day-tanks, totes, drums, vats, reservoirs and other storage vessels. Both hose-barb and direct threaded connections available.



DM-800HFR/L6 Nozzle
Transfer most liquids friendly
with 316 Stainless and Teflon!

Supplier

Specifications & Ordering

Nozzle with 3/4" Barb	Part # DM-800HFR/L6-75B
Nozzle with 1" Barb	Part # DM-800HFR/L6-1B
Inlet Dims:	3/4", or 1.0" (with hose barb)
Optional Base:	3/4", or 1" female NPT
Spout Dims:	0.875 ID x 2.75" L
Wetted parts:	316 stainless, Teflon
Temperature:	Max. 176° F
Flow Rate:	Max. 13.2 GPM
Pressure:	Max. 43.5 Psi.
Net Weight:	2.2 lbs. (1.0 Kg)
Handle Swivel:	Complete 360° swivel

Optional Accessories

Part #	Order Codes	Description
DM-800HFR/L6-R34		Reducer adapter, 1" > 3/4" Npt, SS
DM-800HFR/L6-R1		Reducer adapter, 1.25" > 1" Npt, SS
DM800FXDH34-05		X/D hose, 3/4" Mpt, 5 ft. L, TFE, SS
DM800FXDH34-10		X/D hose, 1" Mpt, 5 ft. L, TFE, SS
DM-166GWK		Grounding kit, 4 cables

When transferring flammable liquids use explosion-proofing grounding kit No. DM-166GWK to ground metal equipment.

DM-800HFR/L6 Series Nozzle, Spare Parts

Part Description	Part #	Qty.
hose connector SS, 3/4"	0151-038	1
hose connector SS, 1"	0151-196	1
hose connector SS, 1-1/4"	0151-197	1
running ring	0204-280	1
guide ring	0204-281	1
stuffing box SS	0204-332	1
threaded nipple	0204-372	1
valve housing SS	0204-375	1
tappet SS assembly, FEP/Viton	0204-378	1
tappet SS assembly, Viton	0204-800	1
bolt with 2 lock washers	0204-657	1
bracket SS	0204-704	1
screw SS	0204-709	1
sealing packing PTFE	0204-710	1
screw	0300-011	2
screw	0300-077	1
wing nut, 1-1/4"	0302-068	1
pressure spring	0310-712	1
seal PTFE O-ring	0313-195	1
Viton o-ring	0314-061	1
o-ring FEP-Viton	0314-164	1
seal ring	0314-204	1
seal PTFE	0314-711	1
protection bow	0343-718	1
lever	0343-719	1
cap	0343-720	1
ball	0370-036	3
o-ring EPDM	0314-064	1
nozzle SS 1-1/4, seal Viton	0204-370	1
nozzle SS 1-1/4, seal FEP/Viton	0204-377	1

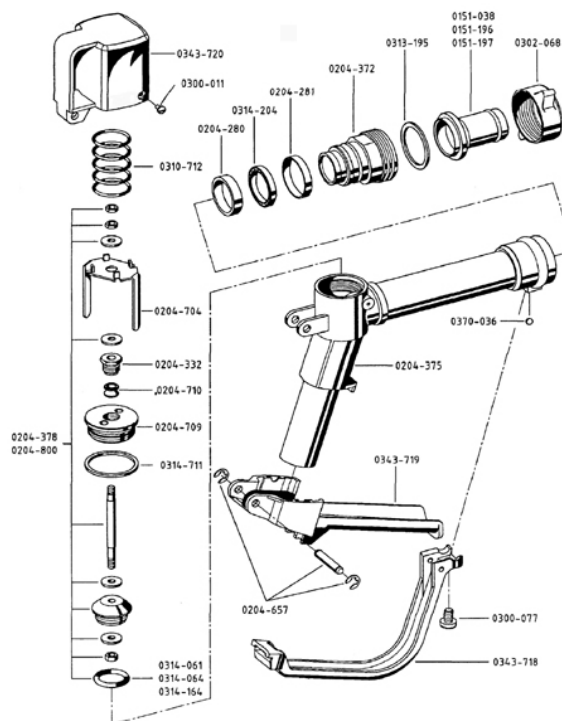

General Safety & Operating Information

The operator must read and follow these operating instructions before using the nozzle.

- The operator must wear suitable protective clothing, face mask, goggles, respiration protection, apron, gloves, boots and other protective clothing or equipment, as necessary, when transferring hazardous liquids.
- Do not point the nozzle at anyone. Mistaken liquid release could cause personal harm, injury or death.
- Ensure the nozzle has full chemical compatibility between 316 stainless steel, Teflon and the transferred liquid.
- Ensure that all connections and fittings are properly tightened. Check for tightness regularly.
- Note the nozzle specification limits for temperature, pressure, viscosity and density of the liquid being pumped.
- Do not use for transferring abrasive filled liquids that could damage seals or internal components.
- US Federal and national accident prevention and fire hazard regulations must be observed without fail.

Nozzle Dispensing Operation

This nozzle is a manually operated hand valve for regulating the quantity of fluid flow. The flow rate can be changed by simply squeezing the valve hand lever with appropriate sensitivity. The stainless steel nozzle is suitable for filling and transferring chemically compatible liquids such as foods, beverages, pharmaceuticals, cosmetics, medical, bio-science materials, agricultural, veterinary liquids, acids, alkalis, solvents, cleaners, high purity solutions and most other industrial liquids including flammable or combustible liquids. The stainless steel nozzle includes a rotary joint on the inlet. This makes it possible to turn the nozzle in the desired direction with rigid hoses.

Operation Warning! --- For All Applications Using Hazardous, Corrosive or Flammable Liquids

The nozzle can be damaged when exceeding the limits for pressure, viscosity, flow and temperature of medium as well as handling unsuitable liquids. Splashing liquid or flying parts can cause injury or death. Observe the specifications listed here. Check that nozzle materials of construction are compatible with any liquids being transferred. Have a Safety or Qualified Engineer rig the nozzle and equipment for flammable or hazardous operations. Fire and/or an explosion can occur when transferring volatile liquids! A blast wave can send flying parts, causing injury or death. When handling flammable liquids all appropriate instructions and guidelines for explosion protection must be observed. A conductive connection between the full and empty containers is achieved by means of a conductive floor (e.g. conductive gratings) or bonding wires. The transition between each container, all equipment and the grounding earth connection must also be conductive. Check and follow the classifications, procedures and rules for processing flammable liquids according NFPA (National Fire Protection Code) #77 and #30 and European directive 67/548/EEC at all times. When pumping flammable liquids, operation safety regulations and the following points must be observed: All equipment must be made from stainless steel or brass or groundable and bondable metal. Ensure bonding and grounding wires are secure before starting any operation. Before starting operation, check continuity to ensure grounded and bonded cables have less than 1 ohm resistance for safe usage. Also Read: "Operating Guidelines" for the DM-166GWK grounding kit.

Repairs Warning!

If the fastening screw for the protective trigger guard and base clamp is missing, the nozzle will not be properly sealed. Leaking or splashing liquid can occur, causing harm, injury or death and environmental damage. Before assembling the protective clamp on the stainless steel nozzle, ensure the 3 ball bearings have been inserted into the rotary joint. You can further protect the fastening screw from coming loose from the protective clamp by apply a suitable thread sealant or threadlock.

When returning any nozzle or component to the supplier, an MSDS sheet is required with a Decontamination Certificate, completely filled out and signed by the owner. DRUM-MATES™ Inc., Fax: 609-261-1034, Email: info@drummates.com

