

2" Double Diaphragm Pump • Food Grade

Model No. DM-DDP/2FGT, 316 Stainless Steel, 2.0" Tri-Clamp Ports

Specifications

Flow Rate adjustable to . . . 0-180 gpm (680 lpm)
PORT SIZE
 Inlet and Discharge 2.0" Tri-Clamp®
Air Inlet 0.50" NPT
Air Exhaust 0.75" NPT
Suction lift
 Teflon® 10' Dry/20' Wet (3.05m/6.10m)
Max. particle size (Dia.) 0.625" (15.88mm)
Surface Finish 32 micro-inch (0.8 micrometer)
Shipping Weight
 Stainless Steel 125 lbs (56.70 kg)



Performance

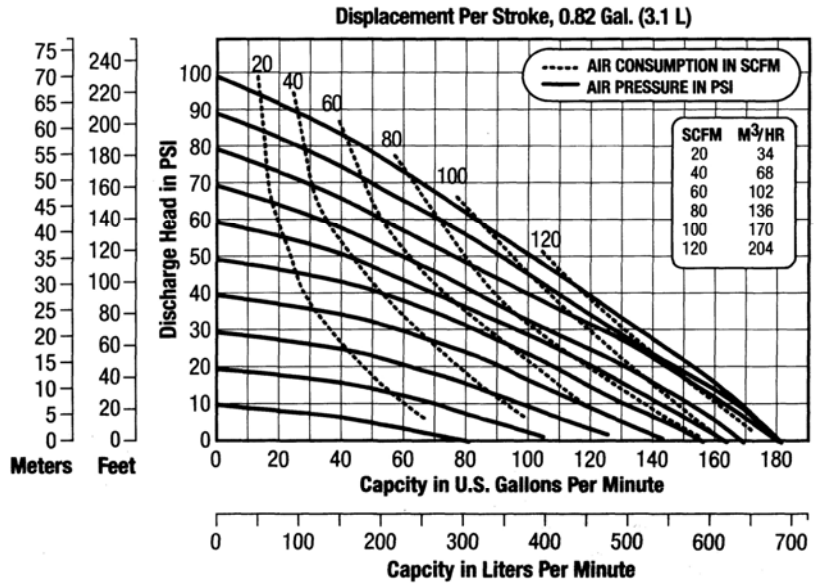

For Teflon diaphragm fitted pump, reduce water discharge by 20%
CAUTION: Do not exceed 125 Psig (8.5 bars) air pressure.

Dimensions

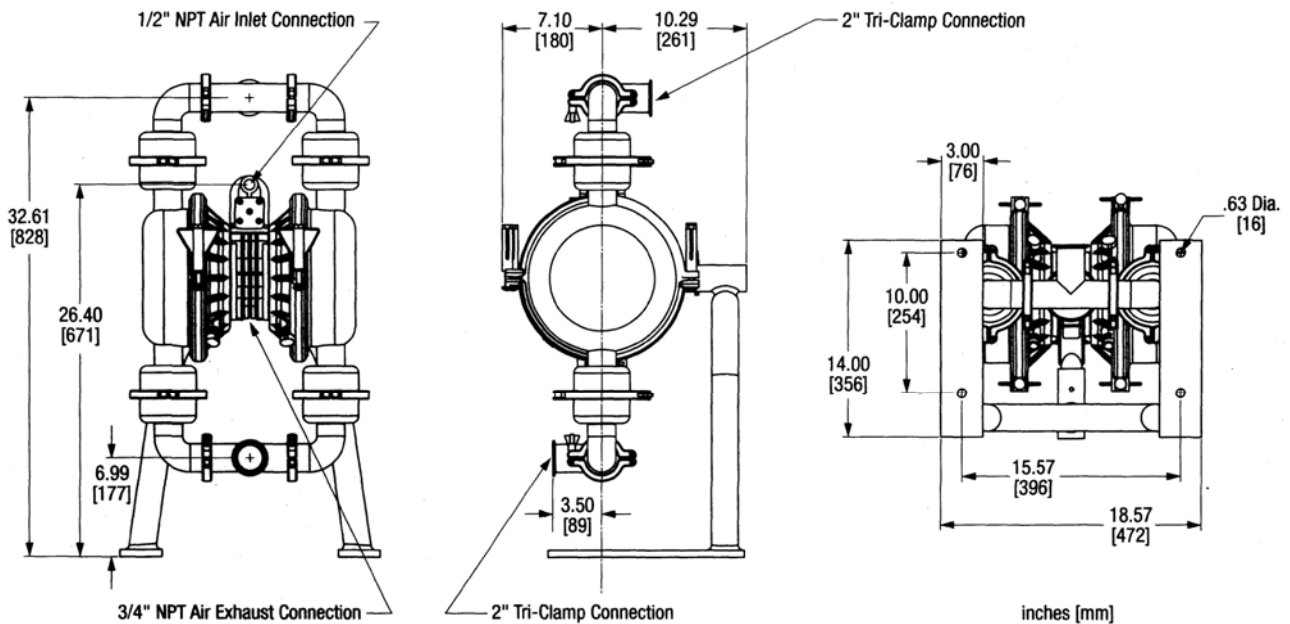

Ask for literature on DRUM-MATES® drum/tote mixers, drum tumblers, drum/tote pumps & hand nozzles.
 DRUM-MATES® Inc., Liquid Processing Equipment Div., Tel: 609-261-1033, Fax: 609-261-1034