

# DM-55DDP/12PP Double Diaphragm Pump

Bolted, 1/2 Port, Max. 14 Gpm, Choice of Polypropylene, Kynar or Teflon



## SPECIFICATIONS

**FLOW RATE** (Adjustable) ..... 0-14 gpm (53 lpm)  
**PORT SIZE**  
 Inlet and Outlet..... 0.50" NPT  
**AIR INLET** ..... 0.375" NPT  
**AIR EXHAUST** ..... 0.375" NPT  
**SUCTION LIFT** .. 15' Dry/25' Wet (6.096m/7.62m)  
 Teflon®..... 5' Dry/10' Wet (1.52m/3.048m)  
**MAX. PARTICLE SIZE** (Dia.) .....0.0625"(1.6mm)  
**SHIPPING WEIGHTS**  
 Polypropylene ..... 10 lbs (4.54 kg)  
 Kynar® ..... 10 lbs (4.54 kg)  
 Teflon® ..... 12 lbs (5.45 kg)

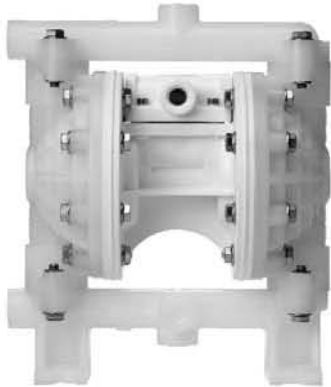

## PERFORMANCE

Determined by actual flow meter tests.

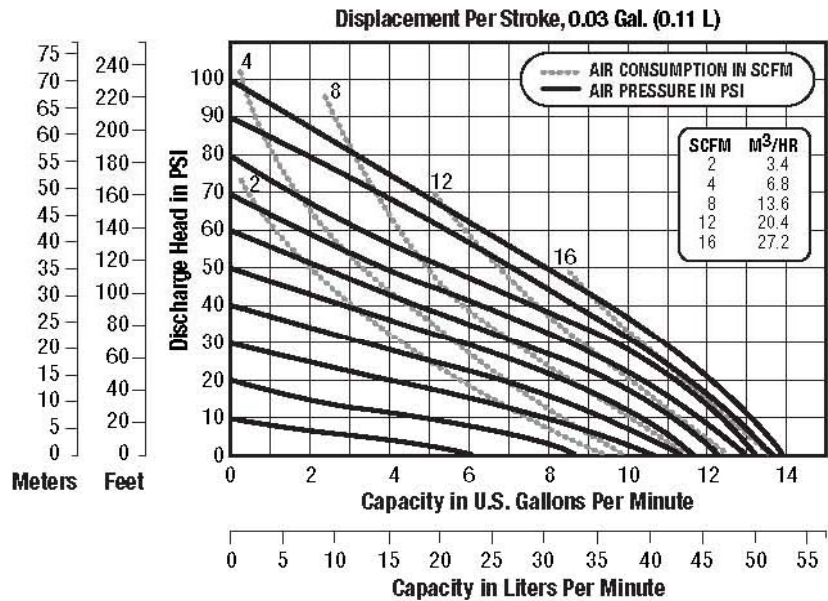

**CAUTION:** Do not exceed 100 psig (6.9 bars) air supply or liquid pressure.

## DIMENSIONS

